



Automated Solar Powered Street Lighting System with Super Capacitors

Alvin T Dela Pena^{*}, Clarissa F Quezon and Christian Q Feliciano

Affiliation: Engineering Department, ACAD, Colegio De San Juan De Letran Bataan, Abucay, Bataan, Philippines

***Corresponding author:** Dela ATP, Engineering Department, ACAD, Colegio De San Juan De Letran Bataan, Abucay, Bataan, Philippines, E-mail: atdelapena@letranbataan.edu.ph

Citation: Dela Pena TA, Quezon FC and Feliciano QC. Automated solar powered street lighting system with super capacitors (2020) Edelweiss Appli Sci Tech 4: 1-4.

Received: Sep 16, 2019

Accepted: Jan 13, 2020

Published: Jan 19, 2020

Copyright: © 2020 Pena ATD, et al., This is an open-access article distributed under the terms of the Creative Commons Attribution License, which permits unrestricted use, distribution, and reproduction in any medium, provided the original author and source are credited.

Abstract

The researchers came up to conduct a study in creating a street lighting system powered up by solar panels that sustains its own power as a stand-alone system off the grid line. By analyzing the collected data regarding the power consumption of the institution where in every 15% increase in the student's population, there is 20% increase in the electric bill consumption rate, that is why the researchers continue to expand their previous study, the charging station that gives an alternative source of electrical energy for mobile devices in the institution, to consider a free energy that can be a source of light during night time, this may lessen the power consumption in the near future not only by supplying mobile devices but by also illuminating the environment of the campus. Two hardware designs were constructed and tested as an initial hardware design to control the lighting system namely; a microcontroller unit that will act as the charge controller for the storage unit and a relay module using discrete components that will also act with the same function.

The study concluded that the installation of a relay module alone as the charge controller to automatically cut-off the full charge voltage and turn on the charging when voltage in the storage unit is drain enhances the power management capability and storage of the lighting system in comparison to the other design which consumes a greater amount of power in operating the sensor control unit 24/7. The charging unit that uses the super capacitors maximizes the charging time into an average of 136.567 minutes compared to the existing design that has twice of its charging time condition which is equivalent to more than six(6) hours. The researchers recommended that the Colegio de San Juan de Letran, Bataan should implement the installation of this project study, or another study for improving the hardware design components of the system which can be extended to the employees, teachers and students of the institution.

Keywords: Photovoltaic cell, Super capacitor, Microcontroller, Relay module and Charge controller.

Introduction

This descriptive study designed a prototype of the Automated Solar Powered Street Lighting System with Super Capacitor that could be installed in Colegio de San Juan de Letran-Bataan. It focused on the development and the evaluation of a lighting system and a sensor device that automatically lights up the lamp at night that can be used by the facility monitoring and security purposes. The research project focused mainly on the hardware assembly design and development of a street light which was powered up by photovoltaic panels in which the electronic control and sensors for the lightings effect is allotted for the components life span and battery management [1]. It has the function of managing the solar energy harnessed from the sun and converting it to an electrical energy by means of a photovoltaic cell module [2].

The storage unit is enhanced through the aid of super capacitors having its fast charging and discharging capability that will support the loading system needed to the 12VDC lead-acid battery which will provide the energy needed in the lighting system [3]. The researcher implemented to use and install the street light at the school considering its geographical location on uplands or highlands where it is more expose to sunlight and accumulates more energy during the charging cycle. The device made might help to enhance the security monitoring done by guards on duty at night by having a more visible environment through this lighting system. The prototype of the automated street light was

installed in the school where-in it expanded to continue the previous study which is also an automated solar powered charging station for mobile devices. This study is another application into the development of a street light which basically charges and stores energy at daytime and utilizes the stored energy by giving off light during nighttime. The electronic hardware setup was designed to be a stand-alone system through solar energy to charge up its own electrical energy into battery and capacitors while it also runs to function simultaneously at daylight and to power up the LED lamp at night [4-7].

From the data gathered regarding the power consumption of the institution, there is 20% increase in the electric bill consumption rate in every 15% increase in the student's population from the previous years of 2016 and 2017 which is why the researcher came up to build a device that might lessen the power consumption in the near future not only by supplying mobile devices' electrical energy through a charging station but also by using this automated solar powered street lights instead of using grid connected street lights. An LED lamp was used to sustain the lighting system which consumes less power and has a longer life span [8,9].

Statement of the Problem

The main problem of this study was to determine the building process of the hardware design of an Automated Solar Powered Street Lighting



System with Super Capacitor in Colegio de San Juan de Letran-Bataan. Specifically, the study sought to answer the following questions:

- How to construct the hardware design using super capacitors, battery and solar panel?
- How to test and evaluate the functionality of the lighting system in terms of its charging and discharging operations through the lamp?
- How to create a charge controller for the storage unit and light sensor device?

Significance of the Study

This study was deemed significant to the following group/ individuals:
School: By implementing this project study, the cost of the electric bill might be decreased by using this device in providing alternative source of renewable energy in illuminating the campus especially at night. The proposed street light will be located at the driveway/vicinity of Colegio de San Juan de Letran-Bataan.

Facility, Auxiliary Staff/Maintenance/Security OIC Personnel: A lighting/ illumination system will be deployed in the vicinity of Colegio de San Juan de Letran-Bataan to enhance the security and monitoring of its environment. This project may help the security guards and the officer in charge for the surveillance and manual roving of the campus by having a more visible sight at night.

Researcher: The researcher expanded and continued to develop a study about renewable energy sources and their knowledge regarding their chosen field of expertise in electronics and also a project investment for an alternative supply of energy and a lighting system off the grid that might be visible in the market.

Future Researcher: This case study will be an essential reference, guide and related literature for providing consistent information regarding the Automated Solar Powered Street Lighting System with Super Capacitor and on the subject renewable alternative energy sources or the related green energy project.

Methodology

This study used a descriptive design. A descriptive research design is a type of research that defines relevant information from a performance and situation of the test subject. An observation method was used to achieve the data gathering from initial testing up to the implementation of the study. This type of technique allows the researcher to record direct measurements of the parameters involved from a current situation such as the voltage and current that flows the system.

The proponents collected data from the current hardware design in terms of its full charging time and its full discharged time operation at night to evaluate and display its descriptive statistics based from the results obtained from the rest of the trials. Data specification of hardware components, facts and literature were obtained also through secondary sources such as websites, books, published and unpublished journals. They also gathered data and relevant information from an interview to office representatives in the institution regarding the electric bills and student population [10] (Figure 1).

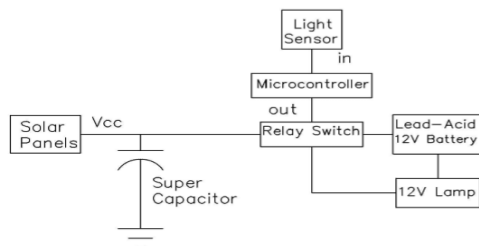

Note: Proposed Two (2) Initial Hardware Designs.
Figure 1: Microcontroller set-up.

It shows the construction of the initial design with the aid of a microcontroller to support the automatic charging cycle of the prototype and also in activating the LED lamp [11]. The street lights operates continuously from daylight due to its charging operation into its battery and at nighttime to discharge the energy in sustaining the lighting (figure 2).

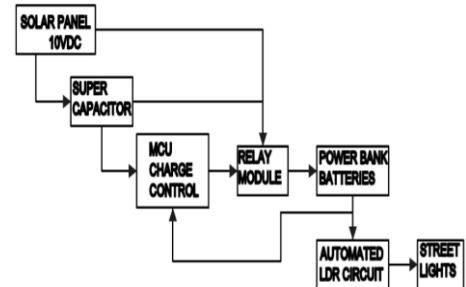

Figure 2: Relay control set-up.

The diagram above shows the second and final design of the hardware design which was controlled by transistor switches which consumes less power compared to the first set-up throughout the rest of the operation. This design was fully implemented for the units of street light to be deployed within the campus. A series of solar panels were combined to maximize the solar energy absorption from daylight and the batteries will sustain the lighting during night time [2]. The storage unit was managed by the charge controller followed by a diode rectifier that allows the passage of current from the absorption of the solar energy [1].

Technical and Economic Study

Presentation of the Solution

Installation of the Relay board module as the Charge Controller:

Technical Description: A Relay is a switch that electrically operates an electromagnet. The electromagnet is activated with a small voltage coming from the signal output of a circuit control and it pulls a contact to make or break a direct current 12V. The source power will be activated or triggered from the main circuit control giving command to the battery and the lamp when to charge and operate continuously.

The actual appearance of the light sensor exposed at daylight and the schematic diagram which shows the transistor switches which controls the activation of relay switches to turn ON or OFF the LED light automatically coming from the information sensed by the light dependent resistor as a sensor device [8]. The relay switch here illustrates the direct connection of normally open (NO stands for normally open) pole from the battery going to the lamp and when the sensor detects darkness that will be the time when the open pole will be closed and the battery will supply energy and power up the lamp and also this is the actual appearance of transistor used for this control system.

The sensor used has a function to activate the street lights at night and to turn the lights off automatically at daylight. They are Light Dependent Resistors (LDR) with sensitivity from daylight or any means of lighting system [11]. This will be the main signal input needed for switching purposes of the lighting system which are directly connected to bipolar junction transistor (BC547) Darlington pair and the biasing technique applied was an inverter switch that cuts off the voltage from a relay switch to the source 12V voltage when daylight was sensed from the LDR. Lead acid 12V batteries were used to supply energy for the lights on at night. The whole storage capacity of the system was having a full charged voltage rate of 14.7 V consumed for maximum of 8 hours average in all the trials recorded (Figure 3).

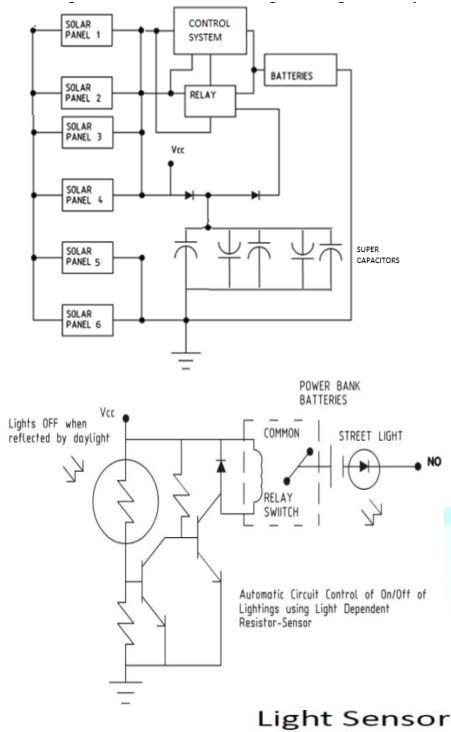

Figure 3: The whole hardware circuit design.

Capacitors were connected in series network 5 pieces 2.7V 500F each which amounts to a total of 18VDC when full charged and relayed transferred to the 12V lead acid battery 400mAh rate. It is possible to extend its storage capacity intended also for functioning as a charging station for mobile devices such as cellphones. It can manage the lack of solar light in 48 hours for totally draining the system without any support of charging straight from the solar only just to support the loading system or lightings.

The device consists of the 12V lamp which represents the loading system of the street light, the concrete stand post which includes the circuit box, 12V lead-acid battery and sensor for automatic lighting sequence control of the lamp and the solar panel above the construction. An LED lamp will be used to provide the illumination system which has a rate of ten to fifteen years life span with less power consumption than traditional lightings [8]. The concrete box protects the circuit control from dusts, dirt, rain, sunlight/heat and any other related factors that would be a threat to the main control of the system device (Figure 4 and Table 1).

The total cost of the material for one complete set up of a street light is Php 7,250.00. In relation to its power consumption rate, a single street lamp post consumes 0.32kWhr/month. Base from the computation table of MERALCO, this consumption gains an amount of Php108.00 per month.

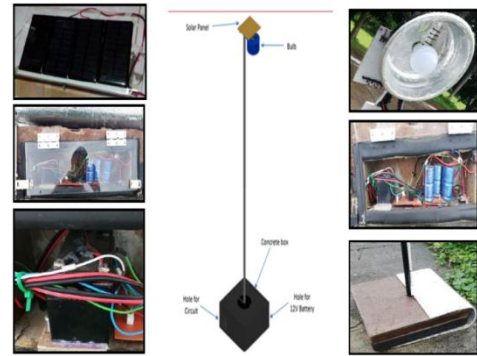

Figure 4: Prototype construction Set-up.

List	Item Name	Quantity	Cost (Philippine-Peso)
1	Labor cost (welding)	1	300
2	Super Caps	4	3500
3	Battery	1	740
4	Solar Panel	3	1200
5	Steel stand accessories	1	1000
6	LED Bulb	1	360
7	Charger circuit module	1	450
	Total		7,250.00

Table 1: Breakdown of the material cost.

Taking into consideration the return of investment will be attained in 68 months or in 5.6 years while the life span of the lighting system can last for standard specification battery and components life of up to fifteen years. MERALCO is an electrical power distributor in the Philippines which is also known as Manila Electric Company. It is Metro Manila's only electric power distributor and holds the power distribution franchise for 22 cities and 89 municipalities, including the whole of the National Capital Region and the exurbs that form Mega Manila.

By having Php108 X 12X5.6=Php, 7,257.00, which balances the material costs of investment. To ensure reliability, the charging control module unit will have a single module set up of the Relay module board to automatically control the charging and discharging of the direct current full load voltage from the super capacitor to the 12VDC battery. The source input supply will be directly connected as the full amount of voltage that will sustain the charging capability of the device into a maximum power transfer from the solar panel to the external load street light LED lamp.

No. of Testing	Date	Recorded time	Full charge time
#		starting point schedule	(Minutes)
1	2-Feb	8:35 AM	211
2	2-Feb	11:16 AM	223
3	9-Feb	8:50 AM	216
4	9-Feb	12:15 PM	218
5	16-Feb	8:47 AM	235
6	16-Feb	12:33 PM	231
7	23-Feb	8:23 AM	221
8	23-Feb	11:32 AM	210
9	2-Mar	8:51 AM	201
10	2-Mar	12:21 PM	215

Note: Solar Power in charging the 12V Lead Acid Battery using MCU (full charge=14V).

Table 2: Accuracy test for charging the battery.



According to the data given above (Table 2), the battery reached its full charge condition in an average of 218.1 minutes using the solar panels alone for the rest of the ten trials.

No. of Testing	Date	Recorded time	Full charge time
#		starting point schedule	(Minutes)
1	9-Mar	7:45 AM	153
2	9-Mar	10:22 AM	145
3	9-Mar	2:17 PM	146
4	16-Mar	7:51 AM	148
5	16-Mar	10:32 AM	149
6	16-Mar	2:27 PM	153
7	23-Mar	7:15 AM	167
8	23-Mar	10:43 AM	173
9	23-Mar	2:26 PM	163
10	30-Mar	7:57 AM	159

Note: Solar Power in charging the 12 V Lead Acid Battery using MCU+Super Capacitor (full charge=14 V), Solar Power in charging Super Capacitors only (full charge=14 V).

Table 3: Accuracy test for charging the super capacitors+battery.

According to the data given above (Table 3), the battery reached its full charge condition at an average of 155.6 Minutes for the rest of the ten trials which is faster than the charging rate of the solar panel alone.

No. of Testing	Date	Recorded time	Full charge time
#		starting point schedule	(Minutes)
1	30-Mar	10:12 AM	142
2	6-Apr	2:24 PM	136
3	6-Apr	8:40 AM	137
4	6-Apr	12:18 PM	144
5	13-Apr	8:49 AM	135
6	13-Apr	12:13 PM	137
7	13-Apr	8:03 AM	152
8	20-Apr	11:02 AM	138
9	20-Apr	8:41 AM	148
10	20-Apr	12:21 PM	151

Note: Solar Power in charging using the Solar panel and Super Capacitors+Relay Module Control.

Table 4: Accuracy test for charging the battery in aid of super capacitor+relay module.

According to the data given above (Table 4), the battery reached its full charge condition in an average of one and a half hour using the solar panels with the combination of stored accumulated energy from capacitors and the relay module for the rest of the ten trials.

No. of Testing	Date	Recorded time	Full discharge time
#		starting point schedule	(hours)
1	31-Mar	18:22 PM	9.25
2	7-Apr	18:24 PM	9.5
3	9-Apr	18:40 PM	9.15
4	16-Apr	18:18 PM	8.75
5	17-Apr	18:49 PM	9.2
6	18-Apr	18:13 PM	9.5
7	19-Apr	18:03 PM	9.3
8	20-Apr	18:02 PM	9.75
9	21-Apr	18:41 PM	9.3
10	22-Apr	18:21 PM	9.2

Table 5: Accuracy Test for the discharge operation at night time of the street light.

According to the data given above (Table 5), the battery reached its full drain condition in an average of 9.29 hours using the solar panels with the combination of stored accumulated energy from the capacitors and the relay module for the rest of the ten trials.

Conclusion

In relation to the findings, the prototype was constructed with super capacitors, solar panel, and a lead acid 12VDC battery to sustain a stand-alone street light system which operates the entire cycle of its function by generating its own energy and to supply power in the control. The relay module was evaluated in terms of its operation of the charging sequence, the automatic turning on and off of the lamp was performed also by the sensor and the accuracy of the system was assessed through the result of its average value for the charging time which is equal to 2.13 hours and its average value for discharge time operation at night to light up the LED lamp is equal to 9.29 hours.

Recommendations

By this study, we recommend that the street light and charging station might be used for another application such as high voltage AC output applications in supplying power for home appliances such as electric fans for small scale applications only by expanding the solar panel array into much higher voltages. In terms of the prototype installation, the hardware construction built was made of concrete box, the circuit case might be improved considering the structure, size and type of the battery and the type of material to be use instead of a concrete structure for a better and easier installation process. For alternative extensive design, the hardware to generate electrical supply of energy might use wind turbine considering its geographical location in high uplands.

References

1. [What Is Solar Power? \(2017\)](#)
2. [Solar Power \(2020\) AENews.](#)
3. Morris N. Solar power (2010) ON: Saunders United States.
4. Oxlade, C. Solar power (2012) Raintree, United Kingdom.
5. Ollhoff J. Solar power (2010) Edina, MN: ABDO Pub, United States.
6. [Hantula R and Voegel D. Solar power \(2010\) NY: Chelsea Clubhouse, United States.](#)
7. Parks PJ. Solar power (2010) San Diego, CA: Reference Point Press, United States.
8. [Inhabitat-Green Design, Innovation, Architecture, Green Building \(2017\).](#)
9. [Discover how you can power your home with clean and affordable solar power energy \(2017\).](#)
10. Ackson SL. Research Methods and Statistics: A Critical Thinking Approach (3rd Edn) (2009) Belmont, CA: Wadsworth, United States.
11. [Complete Solar Power Systems \(2017\).](#)